

Model JAR-0C

Indoor Current Transformer 600 V Auxiliary Current Transformer

Application

Designed for indoor service; for connection in the secondary circuit of a main current transformer to change the effective ratio seen by meters and relays. It's accuracy is suitable for use with totalizing meters and relays. It is designed for use on circuits not exceeding 600 V to ground.

Regulatory Agency Approvals

UL Recognized File E93779

Weight

Transformer (approximate) 10 lbs

Reference Drawings

Outline 0121C33696

Insulation Level

Because it is used in the secondary circuit of another transformer, it has no voltage rating. These transformers receive a 60 Hz, 2.5 kV high potential factory test between each winding and between the windings and ground.



Frequency

50-60 Hz

JAR-0C Product Data

Continuous Thermal Current Rating Factor 1.5 @ 30 °C Ambient, 1.1 @ 55 °C Ambient

ANSI Meter Accuracy Classification, 60 Hz All Models 0.3 at B0.1 and B0.2

Current Ratio (in Amps) Pri:Sec Φ	Internal Burden (Short- Circuit Impedance) VA at Rated Current	Catalog Number	Current Ratio (in Amps) Pri:Sec Φ	Internal Burden (Short- Circuit Impedance) VA at Rated Current	Catalog Number
5:0.100**	6.0	750X101126	5:6.250	ψ	750X101369
5:0.200**	5.7	750X101120	5:7.500	7.3	750X101010
5:0.250**	6.8	750X101118	5:8.000	7.7	750X101009
5:0.500	7.0	750X101106	5:10.000	8.5	750X101003
5:0.625	7.2	750X101101	5:12.500	8.9	750X101002
5:1.000	7.8	750X101088	5:15.000 **	10.7	750X101001
5:1.250	7.8	750X101082	1.000:5	6.8	750X101029
5:1.667	7.8	750X101067	1.667:5	9.0	750X101026
5:2.000	7.8	750X101060	2.500:5	8.2	750X101024
5:2.395	7.8	750X101056	2.875:5	7.0	750X101330
5:2.500	7.3	750X101054	7.500:5	9.1	750X101019
5:2.890	7.1	750X101051	10.000:5	8.5	750X101015
5:3.000	7.8	750X101049	0.500:1	ψ	750X101308
5:3.330	7.5	750X101042	0.923:1	ψ	750X101335
5:3.750	8.0	750X101038	4.000:10	8.3	750X101004
5:4.000	8.5	750X101036	5&5:5 *	8.2	750X101133
5:5.000	8.5	750X101020	5&5&5&5:5 *	8.2	750X101131
5:5.330	8.5	750X101309	5&5&5&5&5:5 *	8.2	750X101129

ψ Refer to factory

ϕ Common ratios are listed in the data table; other ratios are available, consult factory.

* Up to six secondary currents can be totalized. Equal or unequal line current transformers can be summed with these transformers. Consult factory with the ratios of the line current transformers to be totalized.

** Exception: These Ratio Numbers have no accuracy ratings



JAR-0C Dimensions

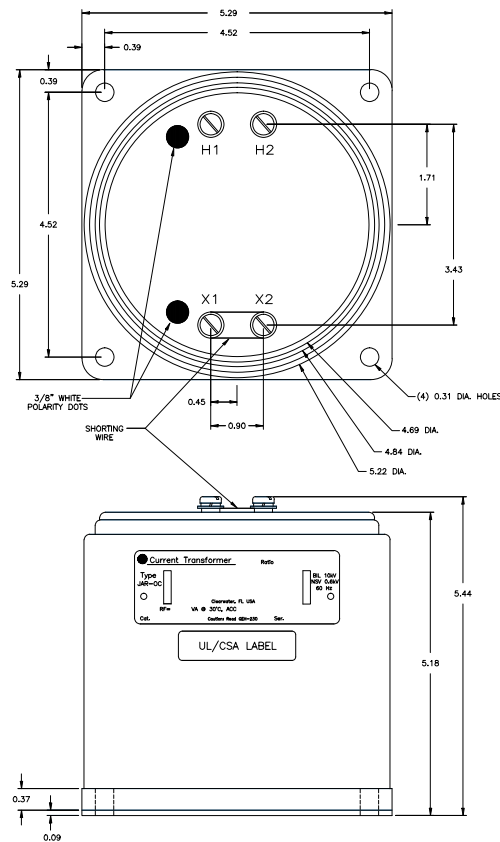

Construction and Insulation

The core and coil are encapsulated in a polyurethane resin. This material has excellent electrical and mechanical properties over a wide temperature range and is resistant to oil and a variety of chemicals.

Core

The core is made from high quality grain oriented silicon steel, annealed under rigidly controlled factory conditions.

Coils

The primary and secondary windings are made of heavy enameled copper wire evenly distributed around the core for maximum accuracy.

Terminals

Both primary and secondary terminals are 10-32 binding head screws, located on the top of the transformer. Primary and secondary terminals are at opposite sides of the case.

Polarity

Primary and secondary polarity terminals are identified with molded characters on top of the transformer case. Multiple secondary windings are marked 1H1, 2H1, etc.

Nameplates

The nameplate is made of polyester material and is attached to the side of the case.

Baseplate and Mounting

The base plate is made from plated steel. The transformer may be mounted by its base plate in any desired position.

Maintenance

These transformers require no maintenance, other than occasional cleaning, if installed where air contamination is severe.

Grid-AIS-L4-ITL_Model_JAR_0C-1393-2017_07-EN. © Copyright 2017. General Electric Company and Instrument Transformers LLC reserve the right to change specifications of described products at any time without notice and without obligation to notify any person of such changes.

